

WIPER AND WASHER SYSTEMS

CONTENTS

	page		page
GENERAL INFORMATION		WIPER SWITCH AND WASHER SWITCH	3
INTRODUCTION	1	DIAGNOSIS AND TESTING	
DESCRIPTION AND OPERATION		INTERMITTENT WIPE RELAY	8
BODY CONTROL MODULE	3	WASHER SYSTEM	6
INTERMITTENT WIPE RELAY	4	WIPER SWITCH AND WASHER SWITCH	7
REAR WIPER AND WASHER SYSTEM	1	WIPER SYSTEM	5
WASHER FLUID LEVEL SENSOR	4	REMOVAL AND INSTALLATION	
WASHER NOZZLE AND PLUMBING	4	INTERMITTENT WIPE RELAY	12
WASHER PUMP	4	WASHER SYSTEM	14
WASHER RESERVOIR	4	WIPER ARM	10
WINDSHIELD WASHER SYSTEM	1	WIPER BLADE AND ELEMENT	9
WINDSHIELD WIPER SYSTEM	1	WIPER LINKAGE AND PIVOT	12
WIPER ARM AND BLADE	2	WIPER MOTOR	11
WIPER LINKAGE AND PIVOT	2	WIPER SWITCH AND WASHER SWITCH	13
WIPER MOTOR	2		

GENERAL INFORMATION

INTRODUCTION

Following are general descriptions of the major components in the wiper and washer systems. Refer to 8W-53 - Wipers in Group 8W - Wiring Diagrams for complete circuit descriptions and diagrams.

DESCRIPTION AND OPERATION

WINDSHIELD WIPER SYSTEM

An intermittent windshield wiper system is standard equipment. This system lets the driver select from either of two wiper speeds, or the intermittent wipe mode. The intermittent wipe mode is provided by delay logic and relay control circuitry contained within the Body Control Module (BCM), and an intermittent wipe relay.

The intermittent wipe mode delay times are speed sensitive. Above about sixteen kilometers-per-hour (ten miles-per-hour) the delay is driver adjustable from about one-half second to about eighteen seconds. Below about sixteen kilometers-per-hour (ten miles-per-hour) the BCM doubles the delay time, or provides delays of about one second to about thirty-six seconds.

Models equipped with the optional automatic headlamp system have a programmable feature in the BCM that will energize the headlamps automatically,

whenever the windshield wipers are turned on. Refer to the proper Diagnostic Procedures manual for more information on enabling or disabling this feature.

The windshield wipers will operate only when the ignition switch is in the Accessory or On positions. A circuit breaker located in the junction block protects the circuitry of the windshield wiper system. Refer to the owner's manual for more information on the windshield wiper system controls and operation.

WINDSHIELD WASHER SYSTEM

An electrically operated windshield washer system is standard equipment. A reservoir in the engine compartment holds the washer fluid, which is pressurized by a pump when the windshield washer (multi-function) switch button is actuated. The windshield washer pump feeds the pressurized washer fluid through the washer system plumbing to the windshield washer nozzles.

Vehicles with the optional Vehicle Information Center (VIC) have a low washer fluid warning feature that will warn the driver when the washer fluid level needs to be checked. Refer to Group 8E - Instrument Panel Systems for more information on this feature.

The washers will operate only when the ignition switch is in the Accessory or On positions. A circuit breaker located in the junction block protects the circuitry of the washer system. Refer to the owner's manual for more information on the windshield washer system controls and operation.

DESCRIPTION AND OPERATION (Continued)

REAR WIPER AND WASHER SYSTEM

A rear wiper and washer system is standard equipment on this model. The rear wiper system provides the following operating modes:

- Intermittent wipe with a five to eight second delay between sweeps.
- Continuous fixed-cycle wipe.
- A park mode that operates the wiper motor until the blade reaches its park position when the rear wiper switch or ignition switch is placed in the Off position, or when the liftgate or liftglass (if the vehicle is so equipped) is opened.
- A rear washer mode that provides two or three wiper blade sweeps before returning to the previously selected rear wiper switch mode.

A single switch in the instrument panel inboard switch pod controls both the rear wiper and washer functions. The rear washer system shares the reservoir of the windshield washer system, but has its own dedicated washer pump and plumbing.

The rear wiper and washer systems will operate only when the ignition switch is in the Accessory or On positions, and when the liftgate and/or optional liftglass are closed. A fuse in the junction block protects the circuitry of both the rear wiper and washer systems.

The rear wiper motor circuitry monitors the liftgate ajar switch and optional liftglass ajar switch circuits. Refer to Group 8Q - Vehicle Theft/Security Systems for more information on the liftgate ajar and liftglass ajar switch circuits. Refer to the owner's manual for more information on the rear wiper and washer system controls and operation.

WIPER ARM AND BLADE

All Grand Cherokee models have two 50.8-centimeter (20-inch) windshield wiper blades with replaceable rubber elements (squeegees). The rear wiper uses a single 30.48-centimeter (12-inch) wiper blade with a non-replaceable rubber element (squeegee).

Caution should be exercised to protect the rubber squeegees from any petroleum-based cleaners or contaminants, which will rapidly deteriorate the rubber. If the squeegees are damaged, worn, or contaminated, the squeegees (front) or the entire wiper blade assembly (rear) must be replaced.

Wiper squeegees exposed to the elements for a long time tend to lose their wiping effectiveness. Periodic cleaning of the squeegees is suggested to remove deposits of salt and road film. The wiper blades, arms, and windshield or rear glass should be cleaned with a sponge or cloth and windshield washer fluid, a mild detergent, or a non-abrasive cleaner. If the squeegees continue to streak or smear, the squeegees (front) or wiper blade (rear) should be replaced.

The blades are mounted to spring-loaded wiper arms. The spring tension of the wiper arms controls the pressure applied to the blades on the glass. The windshield wiper arms are secured by an integral latch to the two wiper pivots on the cowl plenum cover/grille panel at the base of the windshield. The rear wiper arm is secured by a nut under the wiper arm pivot-end cover directly to the rear wiper motor output shaft on the liftgate panel.

The wiper arms and blades cannot be adjusted or repaired. If faulty or damaged, they must be replaced.

WIPER LINKAGE AND PIVOT

The wiper linkage and pivot module is secured with screws to the cowl plenum panel beneath the cowl plenum cover/grille panel. The wiper motor is secured with screws to the center of the linkage and pivot module bracket. The wiper pivots are secured to the ends of the module bracket.

The two wiper pivot crank arms and the wiper motor crank arm each have ball studs on their ends. The motor crank arm ball stud is the longer of the three. Two drive links connect the motor crank arm to the pivot crank arms.

The passenger side drive link has a plastic socket-type bushing on each end. The driver side drive link has a plastic socket-type bushing on one end, and a plastic sleeve-type bushing on the other end.

The socket-type bushing on one end of each drive link is snap-fit over the ball stud on the crank arm of its respective pivot. The driver side drive link sleeve-type bushing end is then fit over the motor crank arm ball stud, and the other socket-type bushing of the passenger side drive link is snap-fit over the exposed end of the motor crank arm ball stud.

The wiper linkage, pivots, bushings, motor crank arm and mounting bracket are only serviced as a complete unit. If any part of this assembly is faulty or damaged, the entire wiper linkage and pivots module must be replaced. The wiper motor is serviced separately.

WIPER MOTOR*FRONT*

The two-speed permanent magnet wiper motor has an integral transmission and park switch. The motor is secured to the wiper linkage and pivot module bracket with three screws. The wiper motor output shaft passes through a hole in the module bracket, where a nut secures the wiper motor crank arm to the motor output shaft.

Wiper speed is controlled by current flow to the proper set of brushes. The wiper motor completes its wipe cycle when the windshield wiper (multi-func-

DESCRIPTION AND OPERATION (Continued)

tion) switch is turned to the Off position, and parks the blades in the lowest portion of the wipe pattern.

The windshield wiper motor cannot be repaired. If faulty or damaged, the entire wiper motor assembly must be replaced. The wiper linkage and pivots module is also available for service.

REAR

The rear wiper motor is secured with two screws and nuts to a bracket on the passenger compartment side of the liftgate inner panel, below the rear glass and behind the liftgate trim panel. The motor output shaft passes through the liftgate outer panel where a gasket, bezel, and nut, seal and secure the unit to the liftgate outer panel. The rear wiper arm is secured directly to the motor output shaft with a nut.

The rear wiper motor unit contains integral electronic controls that provide the following operating modes:

- Intermittent wipe with a five to eight second delay between sweeps.
- Continuous fixed-cycle wipe.
- A park mode that operates the wiper motor until the blade reaches its park position when the rear wiper switch or ignition switch is placed in the Off position, or when the liftgate or liftglass (if the vehicle is so equipped) is opened.
- A rear washer mode that provides two or three wiper blade sweeps before returning to the previously selected rear wiper switch mode.

The rear wiper motor cannot be repaired. If faulty or damaged, the entire rear wiper motor assembly must be replaced.

WIPER SWITCH AND WASHER SWITCH**FRONT**

The windshield wiper and washer switches are contained in the multi-function switch assembly (Fig. 1). The multi-function switch assembly is secured to the left side of the steering column. A knob on the end of the multi-function switch stalk is rotated to select the desired wiper speed or intermittent wipe delay, or depressed toward the steering column to activate the washer system.

The multi-function switch contains circuitry for the following functions:

- Turn signals
- Hazard warning
- Headlamp beam selection
- Headlamp optical horn
- Windshield wipers
- Windshield washers.

The information contained in this group addresses only the switch functions for the windshield wiper and washer systems. For information relative to the other switch functions, refer to the proper group.

However, the multi-function switch cannot be repaired. If any function of the multi-function switch is faulty, or if the switch is damaged, the entire switch assembly must be replaced.

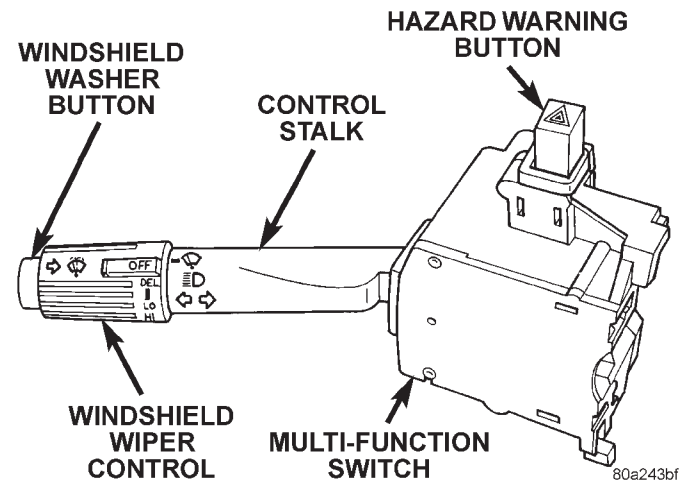

Fig. 1 Multi-Function Switch

REAR

The single two-function rear wiper and washer switch is part of the inboard switch pod unit, which is located on the instrument panel just inboard of the steering column. The rear wiper and washer switch controls the rear wiper and washer functions.

The sliding-type switch features a detent in the On and Delay positions. The switch knob is depressed to activate the rear washer system. Both the rear wiper and rear washer motors will operate continuously for as long as the switch is held in the momentary Wash position.

The rear wiper and washer switch cannot be repaired and, if faulty or damaged, the entire inboard switch pod unit must be replaced.

BODY CONTROL MODULE

A Body Control Module (BCM) is used on this model to control and integrate many of the electronic functions and features included on the vehicle. The BCM contains a central processing unit and interfaces with other modules in the vehicle on the Chrysler Collision Detection (CCD) data bus network.

The CCD data bus network allows the sharing of sensor information. This helps to reduce wire harness complexity, reduce internal controller hardware, and reduce component sensor current loads. At the same time, this system provides increased reliability, enhanced diagnostics, and allows the addition of many new feature capabilities.

Some of the functions and features that the BCM supports and controls are the speed sensitive intermittent wipe, pulse wipe, and wipe-after-wash modes. On models with the optional automatic head-

DESCRIPTION AND OPERATION (Continued)

lamps, the BCM can be programmed to automatically turn on the headlamps when the windshield wipers are turned on. Refer to the proper Diagnostic Procedures manual for more information on enabling or disabling this feature.

The BCM is programmed to energize or de-energize the intermittent wiper relay in response to certain inputs from the multi-function switch and the windshield wiper motor park switch. For the speed sensitive intermittent wiper feature, the BCM also uses an input from the vehicle speed sensor, which is received on the CCD data bus from the Powertrain Control Module (PCM).

The BCM is mounted under the driver side outboard end of the instrument panel, behind the instrument panel support armature and below the outboard switch pod. Refer to Group 8E - Instrument Panel Systems for the removal and installation procedures. For diagnosis of the BCM or the CCD data bus, the use of a DRB scan tool and the proper Diagnostic Procedures manual are recommended. The BCM can only be serviced by an authorized electronic repair station. Refer to the latest Warranty Policies and Procedures manual for a current listing of authorized electronic repair stations.

INTERMITTENT WIPE RELAY

The intermittent wiper relay is a International Standards Organization (ISO) micro-relay. The terminal designations and functions are the same as a conventional ISO relay. However, the micro-relay terminal orientation (or footprint) is different, current capacity is lower, and the relay case dimensions are smaller than those of the conventional ISO relay.

The intermittent wiper relay is a electromechanical device that switches battery current to the windshield wiper motor or wiper motor park switch when the relay coil is grounded by the Body Control Module (BCM) in response to inputs from the windshield wiper (multi-function) switch. See the Diagnosis and Testing section of this group for more information on the intermittent wiper relay.

The intermittent wiper relay is located in the Power Distribution Center (PDC), in the engine compartment. Refer to the PDC label for relay identification and location.

The intermittent wiper relay cannot be repaired and, if faulty or damaged, it must be replaced.

WASHER RESERVOIR

A single washer fluid reservoir is used for both the front and rear washer systems. The washer fluid reservoir is secured to the inner fender shield, behind the left front wheelhouse in the engine compartment.

Each washer pump and motor unit has a threaded nipple, which is installed through a rubber grommet

seal inserted in a hole near the bottom of the reservoir. A plastic nut and washer that secures the washer pump nipple from the inside of the reservoir, can be accessed through the reservoir filler neck.

The washer reservoir also has a provision for a washer fluid level sensor. The sensor mounts in a hole in the side of the reservoir that is nearest to the dash panel. Refer to Group 8E - Instrument Panel Systems for diagnosis of the sensor.

The washer reservoir, filler cap, and sensor are each available for service.

WASHER PUMP

The washer pumps and motors are mounted near the bottom of the washer reservoir. A threaded nipple on the pump housing passes through a rubber grommet seal installed in a hole near the bottom of the reservoir. A plastic nut and washer secures the washer pump nipple from the inside of the reservoir.

A permanently lubricated and sealed motor is coupled to a rotor-type pump. Washer fluid is gravity-fed from the reservoir to the pump. When the motor is energized, the pump pressurizes the washer fluid and forces it through the plumbing to the nozzles.

The washer pump and motor unit cannot be repaired. If faulty, the entire washer pump and motor unit must be replaced.

WASHER FLUID LEVEL SENSOR

The standard washer fluid level sensor is mounted on the back side of the washer reservoir. A barbed nipple on the sensor is press-fit into a rubber grommet seal installed in a hole in the back of the reservoir.

When the fluid level in the reservoir falls below the pivoting float on the sensor, the float changes position and closes the internal switch contacts of the sensor. Refer to Group 8E - Instrument Panel Systems for diagnosis of the low washer fluid warning lamp and circuit, including the sensor.

The washer fluid level sensor cannot be repaired. If faulty or damaged, the sensor unit must be replaced.

WASHER NOZZLE AND PLUMBING

FRONT

Pressurized washer fluid is fed through a single hose, attached to a barbed nipple on the front washer pump. The hose is routed to a tee fitting located in the cowl plenum area, beneath the cowl plenum cover/grille panel. Hoses from the tee fitting are routed to the two nozzles, which are snapped into openings in the cowl plenum cover/grille panel, below the windshield.

The two fluidic washer nozzles are not adjustable. The nozzles and hose fittings cannot be repaired and, if faulty or damaged, they must be replaced.

DESCRIPTION AND OPERATION (Continued)

REAR

Pressurized washer fluid is fed through a single hose, attached to a barbed nipple on the rear washer pump. The hose is routed from the front of the vehicle to the liftgate with the left side body wire harness.

Above the liftgate opening the hose connects to a check valve, which prevents washer fluid drain-back or siphoning from occurring. From the check valve, another single hose is routed through grommets in holes in the upper liftgate opening panel and the liftgate inner panel to the washer nozzle. The washer nozzle snaps into a hole in the liftgate outer panel, above the liftgate glass.

The rear washer nozzle cannot be adjusted. The nozzle, check valve, and hose fittings cannot be repaired and, if faulty or damaged, they must be replaced.

DIAGNOSIS AND TESTING

WIPER SYSTEM

FRONT

If the problem being diagnosed involves only the pulse wipe or wipe-after-wash modes, see the Washer System diagnosis in this group. For circuit descriptions and diagrams, refer to 8W-53 - Wipers in Group 8W - Wiring Diagrams.

WARNING: ON VEHICLES EQUIPPED WITH AIRBAGS, REFER TO GROUP 8M - PASSIVE RESTRAINT SYSTEMS BEFORE ATTEMPTING ANY STEERING WHEEL, STEERING COLUMN, OR INSTRUMENT PANEL COMPONENT DIAGNOSIS OR SERVICE. FAILURE TO TAKE THE PROPER PRECAUTIONS COULD RESULT IN ACCIDENTAL AIRBAG DEPLOYMENT AND POSSIBLE PERSONAL INJURY.

(1) Disconnect and isolate the battery negative cable. Remove the circuit breaker from the junction block. Connect the battery negative cable. Turn the ignition switch to the On position. Check for battery voltage at the battery side of the circuit breaker. If OK, reinstall the circuit breaker and go to Step 2. If not OK, repair the circuit from the ignition switch as required.

(2) Turn the ignition switch to the On position. Check for battery voltage at the wiper system side of the circuit breaker. If OK, go to Step 3. If not OK, replace the faulty circuit breaker.

(3) Turn the ignition switch to the Off position. Disconnect and isolate the battery negative cable. Unplug the multi-function switch wire harness connector. Connect the battery negative cable. Turn the

ignition switch to the On position. Check for battery voltage at the fused ignition switch output (F86) circuit cavity of the multi-function switch wire harness connector. If OK, go to Step 4. If not OK, repair the open circuit to the circuit breaker as required.

(4) If the problem being diagnosed involves only the intermittent wipe feature, go to Step 5. If the problem being diagnosed involves all wiper modes, or only the Low and/or High speed modes, go to Step 7.

(5) Turn the ignition switch to the Off position. Disconnect and isolate the battery negative cable. Unplug the white 24-way Body Control Module (BCM) wire harness connector. Check for continuity between the wiper switch mode sense cavities of the multi-function switch wire harness connector and the BCM white 24-way wire harness connector. There should be continuity. If OK, go to Step 6. If not OK, repair the open circuit as required.

(6) Unplug the black 24-way BCM wire harness connector. Check for continuity between the windshield wiper switch signal cavities of the multi-function switch wire harness connector and the BCM black 24-way wire harness connector. There should be continuity. If OK, see the Intermittent Wipe Relay diagnosis in this group. If not OK, repair the open circuit as required.

(7) Check for continuity between the two wiper switch low speed output circuit cavities of the multi-function switch wire harness connector. There should be continuity. If OK, go to Step 8. If not OK, repair the open circuit as required.

(8) Test the wiper switch, as described in this group. If the switch tests OK, plug in the multi-function switch wire harness connector and go to Step 9. If not OK, replace the faulty switch and test the wiper system operation. If still not OK, go to Step 9.

(9) Turn the ignition switch to the Off position. Disconnect and isolate the battery negative cable. Move the wiper module far enough to access the wiper motor wire harness connector, as described in this group. Measure the resistance between the ground circuit cavity of the wiper motor wire harness connector and a good ground. The meter should read zero ohms. If OK, go to Step 10. If not OK, repair the circuit to ground as required.

(10) Connect the battery negative cable. Turn the ignition switch to the On position. Place the multi-function switch in the positions indicated in the tests below, and check for battery voltage at the wiper motor wire harness connector.

(a) Check for battery voltage at the fused ignition switch output circuit cavity of the wiper motor wire harness connector with the wiper switch in any position. If OK, go to Step 2. If not OK, repair the open circuit as required.

DIAGNOSIS AND TESTING (Continued)

(b) Check for battery voltage at the wiper switch low speed output circuit cavity of the wiper motor wire harness connector with the wiper switch in the Low position. If OK, go to Step 3. If not OK, repair the open circuit as required.

(c) Check for battery voltage at the wiper switch high speed output circuit cavity of the wiper motor wire harness connector with the wiper switch in the High position. If OK, go to Step 4. If not OK, repair the open circuit as required.

(d) Check for battery voltage at the wiper park switch sense circuit cavity of the wiper motor wire harness connector with the wiper switch in the Low or High position, then move the switch to the Off position. The meter should switch between battery voltage and zero volts while the wipers are cycling. The meter should read battery voltage when the switch is moved to the Off position until the wipers park, and then read a steady zero volts. If not OK, replace the faulty wiper motor.

REAR

For circuit descriptions and diagrams, refer to 8W-53 - Wipers in Group 8W - Wiring Diagrams.

WARNING: ON VEHICLES EQUIPPED WITH AIRBAGS, REFER TO GROUP 8M - PASSIVE RESTRAINT SYSTEMS BEFORE ATTEMPTING ANY STEERING WHEEL, STEERING COLUMN, OR INSTRUMENT PANEL COMPONENT DIAGNOSIS OR SERVICE. FAILURE TO TAKE THE PROPER PRECAUTIONS COULD RESULT IN ACCIDENTAL AIRBAG DEPLOYMENT AND POSSIBLE PERSONAL INJURY.

(1) Check the fuse in the junction block. If OK, go to Step 2. If not OK, repair the shorted circuit or component as required and replace the faulty fuse.

(2) Turn the ignition switch to the On position. Check for battery voltage at the fused ignition switch output circuit cavity of the rear wiper switch wire harness connector. If OK, go to Step 3. If not OK, repair the open circuit as required.

(3) Turn the ignition switch to the Off position. Disconnect and isolate the battery negative cable. Remove and test the rear wiper switch, as described in this group. If OK, go to Step 4. If not OK, replace the faulty switch.

(4) Remove the liftgate inner trim panel. Measure the resistance between the ground circuit cavity of the rear wiper motor wire harness connector and a good ground. The meter should read zero ohms. If OK, go to Step 5. If not OK, repair the circuit to ground as required.

(5) Check for continuity between the liftgate ajar switch sense cavity of the rear wiper motor wire harness connector and a good ground. There should be

continuity with the liftgate and/or the liftglass (if the vehicle is so equipped) open, and no continuity with the liftgate and the liftglass closed. If OK, go to Step 6. If not OK, repair the liftgate and/or the liftglass ajar circuit or switch as required.

(6) Plug in the rear wiper switch wire harness connector. Connect the battery negative cable. Turn the ignition switch to the On position. Place the rear wiper switch in the Wipe position. Check for battery voltage at the rear wiper motor control circuit cavity of the rear wiper motor wire harness connector. Repeat the test for the rear wiper motor control (intermittent) circuit cavity with the rear wiper switch in the Intermittent position, then at the rear washer motor control circuit cavity with the rear wiper switch in the Wash position. In each case, the meter should read battery voltage. If OK, replace the faulty rear wiper motor. If not OK, repair the open circuit(s) as required.

WASHER SYSTEM*FRONT*

The diagnosis found here addresses an inoperative washer pump or wipe-after-wash feature. If the washer pump operates, but no washer fluid is emitted from the washer nozzles, be certain to check the fluid level in the reservoir. Check for ice or other foreign material in the reservoir, and for pinched, disconnected, broken, or incorrectly routed washer system plumbing. For circuit descriptions and diagrams, refer to 8W-53 - Wipers in Group 8W - Wiring Diagrams.

WARNING: ON VEHICLES EQUIPPED WITH AIRBAGS, REFER TO GROUP 8M - PASSIVE RESTRAINT SYSTEMS BEFORE ATTEMPTING ANY STEERING WHEEL, STEERING COLUMN, OR INSTRUMENT PANEL COMPONENT DIAGNOSIS OR SERVICE. FAILURE TO TAKE THE PROPER PRECAUTIONS COULD RESULT IN ACCIDENTAL AIRBAG DEPLOYMENT AND POSSIBLE PERSONAL INJURY.

(1) Turn the ignition switch to the On position. Turn the wiper switch to the Low or High speed position. Check whether the wipers operate. If OK, go to Step 2. If not OK, see the Wiper System diagnosis in this group.

(2) Turn the wiper switch to the Off position. Depress the washer switch for less than one-half second. The wipers should operate for one sweep cycle and then park. Depress the washer switch for more than one-half second. The washer pump should operate and the wipers should operate for two sweep cycles after the switch is released before they park. If the wipers are OK, but the washers are not, go to

DIAGNOSIS AND TESTING (Continued)

Step 3. If the washers are OK, but the wipers are not, go to Step 5.

(3) Turn the ignition switch to the Off position. Disconnect and isolate the battery negative cable. Unplug the front washer pump wire harness connector. Measure the resistance between the ground circuit cavity of the front washer pump wire harness connector and a good ground. The meter should read zero ohms. If OK, go to Step 4. If not OK, repair the ground circuit as required.

(4) Connect the battery negative cable. Turn the ignition switch to the On position. Depress the washer switch. Measure the voltage at the washer switch output circuit cavity of the front washer pump wire harness connector. The meter should read battery voltage. If OK, replace the faulty pump. If not OK, repair the open circuit as required.

(5) Turn the ignition switch to the Off position. Disconnect and isolate the battery negative cable. Unplug the white 24-way wire harness connector from the Body Control Module (BCM). Connect the battery negative cable. Turn the ignition switch to the On position. Depress the washer switch. Check for battery voltage at the washer switch output circuit cavity of the white 24-way BCM wire harness connector. If OK, see the Intermittent Wipe Relay diagnosis in this group. If not OK, repair the open circuit as required.

REAR

The diagnosis found here addresses an inoperative washer pump. If the washer pump operates, but no washer fluid is emitted from the washer nozzles, be certain to check the fluid level in the reservoir. Check for ice or other foreign material in the reservoir, and for pinched, disconnected, broken, or incorrectly routed washer system plumbing. For circuit descriptions and diagrams, refer to 8W-53 - Wipers in Group 8W - Wiring Diagrams.

WARNING: ON VEHICLES EQUIPPED WITH AIR-BAGS, REFER TO GROUP 8M - PASSIVE RESTRAINT SYSTEMS BEFORE ATTEMPTING ANY STEERING WHEEL, STEERING COLUMN, OR INSTRUMENT PANEL COMPONENT DIAGNOSIS OR SERVICE. FAILURE TO TAKE THE PROPER PRECAUTIONS COULD RESULT IN ACCIDENTAL AIR-BAG DEPLOYMENT AND POSSIBLE PERSONAL INJURY.

(1) Turn the ignition switch to the On position. Place the rear wiper/washer switch in the Wipe position. Check whether the rear wiper is operating. If OK, go to Step 2. If not OK, see the Wiper System diagnosis in this group.

(2) Turn the ignition switch to the Off position. Disconnect and isolate the battery negative cable.

Unplug the rear washer pump wire harness connector. Measure the resistance between the ground circuit cavity of the rear washer pump wire harness connector and a good ground. The meter should read zero ohms. If OK, go to Step 3. If not OK, repair the circuit to ground as required.

(3) Connect the battery negative cable. Turn the ignition switch to the On position. Depress the rear washer switch. Measure the voltage at the rear washer motor control circuit cavity of the rear washer pump wire harness connector. The meter should read battery voltage. If OK, replace the faulty pump. If not OK, repair the open circuit as required.

WIPER SWITCH AND WASHER SWITCH

FRONT

Perform the diagnosis for the windshield wiper system and/or washer system as described in this group before testing the multi-function switch. For circuit descriptions and diagrams, see 8W-53 - Wipers in Group 8W - Wiring Diagrams.

WARNING: ON VEHICLES EQUIPPED WITH AIR-BAGS, REFER TO GROUP 8M - PASSIVE RESTRAINT SYSTEMS BEFORE ATTEMPTING ANY STEERING WHEEL, STEERING COLUMN, OR INSTRUMENT PANEL COMPONENT DIAGNOSIS OR SERVICE. FAILURE TO TAKE THE PROPER PRECAUTIONS COULD RESULT IN ACCIDENTAL AIR-BAG DEPLOYMENT AND POSSIBLE PERSONAL INJURY.

(1) Disconnect and isolate the battery negative cable.

(2) Unplug the multi-function switch wire harness connector from the multi-function switch.

(3) Using an ohmmeter, perform the switch continuity checks at the switch terminals as shown in the Multi-Function Switch Continuity chart (Fig. 2).

(4) If the switch fails any of the continuity checks, replace the faulty switch. If the switch is OK, repair the wiper system and/or washer system wire harness circuits as required.

REAR

Perform the diagnosis for the rear wiper system and/or washer system as described in this group before testing the rear wiper and washer switch. For circuit descriptions and diagrams, see 8W-53 - Wipers in Group 8W - Wiring Diagrams.

DIAGNOSIS AND TESTING (Continued)

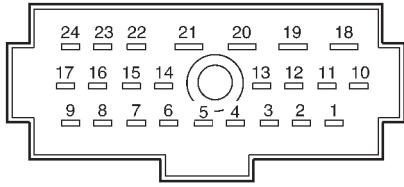

MULTIFUNCTION SWITCH PINS

SWITCH POSITION	CONTINUITY BETWEEN
OFF	PIN 6 AND PIN 7
DELAY	PIN 8 AND PIN 9 PIN 2 AND PIN 4 PIN 1 AND PIN 2 PIN 1 AND PIN 4
LOW	PIN 4 AND PIN 6
HIGH	PIN 4 AND PIN 5
WASH	PIN 3 AND PIN 4

*RESISTANCE AT MAXIMUM DELAY POSITION SHOULD BE BETWEEN 210,000 OHMS AND 390,000 OHMS.
*RESISTANCE AT MINIMUM DELAY POSITION SHOULD BE ZERO WITH OHMMETER SET ON HIGH OHM SCALE.

80a243cb

Fig. 2 Multi-Function Switch Continuity

WARNING: ON VEHICLES EQUIPPED WITH AIR-BAGS, REFER TO GROUP 8M - PASSIVE RESTRAINT SYSTEMS BEFORE ATTEMPTING ANY STEERING WHEEL, STEERING COLUMN, OR INSTRUMENT PANEL COMPONENT DIAGNOSIS OR SERVICE. FAILURE TO TAKE THE PROPER PRECAUTIONS COULD RESULT IN ACCIDENTAL AIR-BAG DEPLOYMENT AND POSSIBLE PERSONAL INJURY.

(1) Remove the rear wiper and washer switch from the instrument panel.

(2) Using an ohmmeter, check the rear wiper and washer switch continuity at the switch terminals as follows:

a. With the switch in the Off position, there should be no continuity between any two switch terminals.

b. With the switch knob depressed in the Wash position, there should be continuity between the fused ignition switch output circuit and the rear washer motor control circuit terminals.

c. With the switch in the Intermittent position, there should be continuity between the fused ignition switch output circuit and the rear wiper motor control (intermittent) circuit terminals.

d. With the switch in the On position, there should be continuity between the fused ignition switch output circuit and the rear wiper motor control circuit terminals.

(3) If the switch fails any of the continuity checks, replace the faulty switch. If the switch is OK, repair the rear wiper system and/or washer system wire harness circuits as required.

INTERMITTENT WIPE RELAY

For circuit descriptions and diagrams, refer to 8W-53 - Wipers in Group 8W - Wiring Diagrams.

WARNING: ON VEHICLES EQUIPPED WITH AIR-BAGS, REFER TO GROUP 8M - PASSIVE RESTRAINT SYSTEMS BEFORE ATTEMPTING ANY STEERING WHEEL, STEERING COLUMN, OR INSTRUMENT PANEL COMPONENT DIAGNOSIS OR SERVICE. FAILURE TO TAKE THE PROPER PRECAUTIONS COULD RESULT IN ACCIDENTAL AIR-BAG DEPLOYMENT AND POSSIBLE PERSONAL INJURY.

RELAY TEST

The intermittent wipe relay (Fig. 3) is located in the Power Distribution Center (PDC) in the engine compartment. Refer to the PDC label for intermittent wipe relay identification and location.

Remove the intermittent wipe relay from the PDC as described in this group to perform the following tests:

(1) A relay in the de-energized position should have continuity between terminals 87A and 30, and no continuity between terminals 87 and 30. If OK, go to Step 2. If not OK, replace the faulty relay.

(2) Resistance between terminals 85 and 86 (electromagnet) should be 75 ± 5 ohms. If OK, go to Step 3. If not OK, replace the faulty relay.

(3) Connect a battery to terminals 85 and 86. There should now be continuity between terminals 30 and 87, and no continuity between terminals 87A and 30. If OK, see the Relay Circuit Test in this group. If not OK, replace the faulty relay.

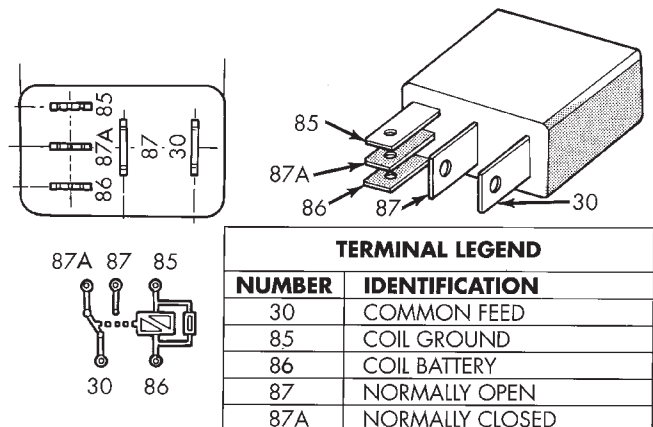

9514-16

Fig. 3 Intermittent Wipe Relay

RELAY CIRCUIT TEST

(1) The relay common feed terminal cavity (30) is connected to the wiper (multi-function) switch. There should be continuity between the cavity for relay ter-

DIAGNOSIS AND TESTING (Continued)

terminal 30 and the two fused ignition switch output (V6) circuit cavities of the multi-function switch connector at all times. If OK, go to Step 2. If not OK, repair the open circuit(s) to the multi-function switch as required.

(2) The relay normally closed terminal (87A) is connected to terminal 30 in the de-energized position. There should be continuity between the cavity for relay terminal 87A and the wiper park switch sense circuit cavities of the wiper motor wire harness connector and the white 24-way Body Control Module (BCM) wire harness connector at all times. If OK, go to Step 3. If not OK, repair the open circuit(s) to the wiper motor and BCM as required.

(3) The relay normally open terminal (87) is connected to the common feed terminal (30) in the energized position. There should be battery voltage at the cavity for relay terminal 87 with the ignition switch in the On or Accessory positions. If OK, go to Step 4. If not OK, repair the open circuit to the ignition switch as required.

(4) The coil battery terminal (86) is connected to the electromagnet in the relay. There should be battery voltage at the cavity for relay terminal 86 with the ignition switch in the On or Accessory positions. If OK, go to Step 5. If not OK, repair the open circuit to the ignition switch as required.

(5) The coil ground terminal (85) is connected to the electromagnet in the relay. It is grounded by the BCM to energize the relay and cycle the wiper motor. Check for continuity between the cavity for relay terminal 85 and the intermittent wiper relay control circuit cavity of the white 24-way BCM wire harness connector. There should be continuity. If OK, refer to the proper Diagnostic Procedures manual for diagnosis of the BCM. If not OK, repair the open circuit to the BCM as required.

REMOVAL AND INSTALLATION

WIPER BLADE AND ELEMENT

FRONT

NOTE: The pinch-release retainer end of the wiper element should always be oriented towards the end of the wiper blade that is nearest to the wiper pivot.

To remove the windshield wiper blade and/or element, proceed as follows:

(1) Turn the windshield wiper switch to the On position. By turning the ignition switch to the On and Off positions, cycle the wiper blades to a convenient working location on the windshield.

(2) Lift the wiper arm to raise the wiper blade and element off of the windshield glass.

(3) Remove the wiper blade from the wiper arm, or the wiper element from the wiper blade as follows:

(a) To remove the wiper blade from the wiper arm, push the release tab under the arm tip and slide the blade away from the tip towards the pivot end of the arm (Fig. 4).

(b) To remove the wiper element from the wiper blade, pinch the notched retainer (pivot) end of the wiper element tightly between the thumb and forefinger (Fig. 5). Then, pull the element firmly towards the wiper pivot to release the wiper blade claws from the wiper element retaining pockets. Once the claws are released from the retaining pockets, the element will slide easily out of the remaining claws.

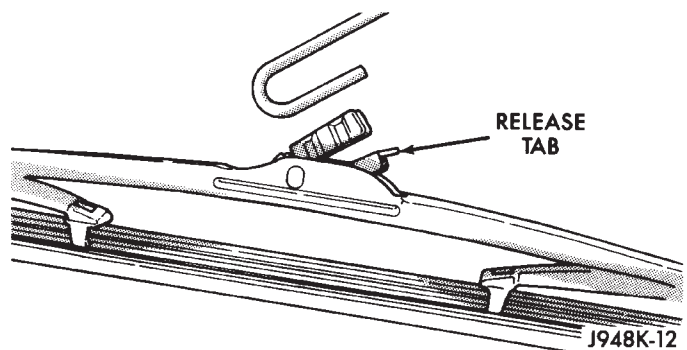

Fig. 4 Wiper Blade Remove/Install - Typical

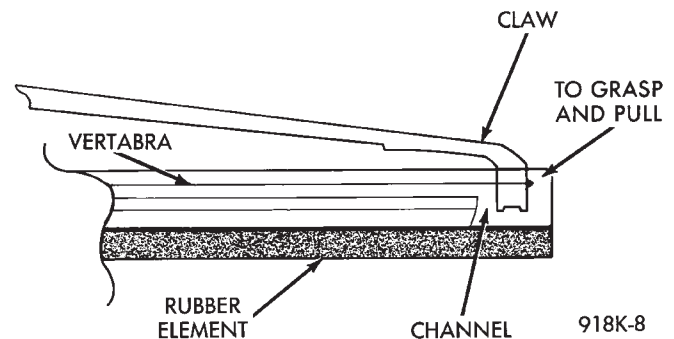

Fig. 5 Wiper Element Remove

(4) Install the wiper blade on the wiper arm, or the wiper element in the wiper blade as follows:

(a) To install the wiper blade on the wiper arm, slide the blade retainer into the U-shaped formation on the tip of the wiper arm until the release tab snaps into its locked position. Be certain that the pinch-release for the wiper element is oriented towards the end of the wiper blade that is nearest to the wiper pivot.

(b) To install the wiper element in the wiper blade, be certain that the metal element rails (vertebra) are properly seated in the slots on either side of the rubber element. Start at the wiper pivot end of the blade and slide the element through each pair of wiper blade claws. The element is fully

REMOVAL AND INSTALLATION (Continued)

installed when the claws on the wiper pivot end of the blade are engaged in the wiper element retaining pockets.

REAR

The rear wiper blade and element are serviced as a unit. If either the blade or the element is faulty or damaged, the entire unit must be replaced. To remove the rear wiper blade, proceed as follows:

(1) Lift the rear wiper arm to raise the wiper blade and element off of the liftgate glass.

(2) Push the release tab under the arm tip and slide the blade away from the tip towards the rear wiper motor output shaft end of the arm (Fig. 4).

(3) To install the wiper blade on the wiper arm, slide the blade retainer into the U-shaped formation on the tip of the wiper arm until the release tab snaps into its locked position. Be certain that the pinch-release clip for the wiper element is oriented towards the end of the wiper blade that is nearest to the rear wiper motor output shaft.

WIPER ARM

CAUTION: The use of a screwdriver or other prying tool to remove a wiper arm may distort it. This distortion could allow the arm to come off of the pivot shaft, regardless of how carefully it is installed.

FRONT

(1) Open the hood of the vehicle.

(2) Lift the wiper arm to permit the latch to be pulled out to its holding position, then release the arm (Fig. 6). The arm will remain off the windshield with the latch in this position.

(3) Remove the arm from the pivot using a rocking motion.

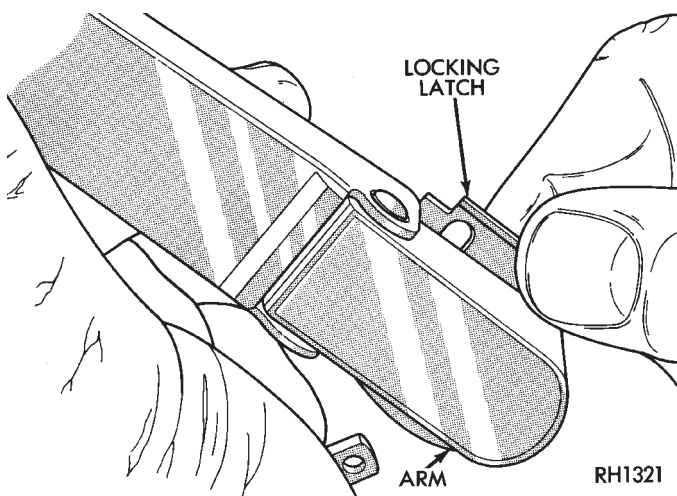

Fig. 6 Wiper Arm Remove/Install

(4) Install the arm and blade with the wiper motor in the Park position. See the Front Wiper Arm Installation illustration (Fig. 7).

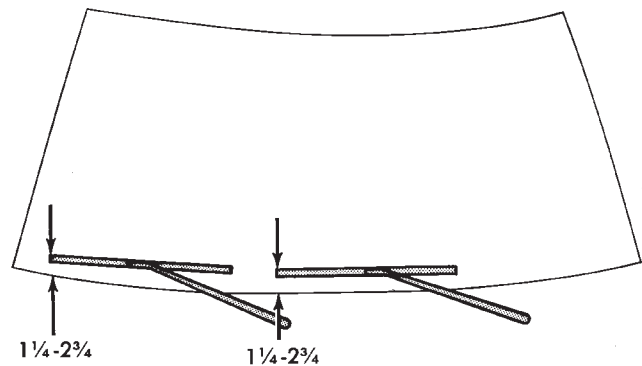

Fig. 7 Front Wiper Arm Installation

(5) Mount the arms on the pivot shafts so that the distance from the lower edge of the wiper arm tip to the upper edge of the lower windshield moulding is:

- 25 to 52 mm (0.98 to 2.04 inch) on the driver side
- 33 to 62 mm (1.29 to 2.44 inch) on the passenger side.

(6) Lift the wiper arm away from the windshield slightly to relieve the spring tension on the latch. Push the latch into the locked position and slowly release the arm until the wiper blade rests on the windshield.

(7) Operate the wipers with the windshield glass wet, then turn the wiper switch to the Off position. Check for the correct wiper arm positioning and readjust if required.

REAR

(1) Remove the wiper arm assembly by lifting the pivot cover and removing the retaining nut (Fig. 8).

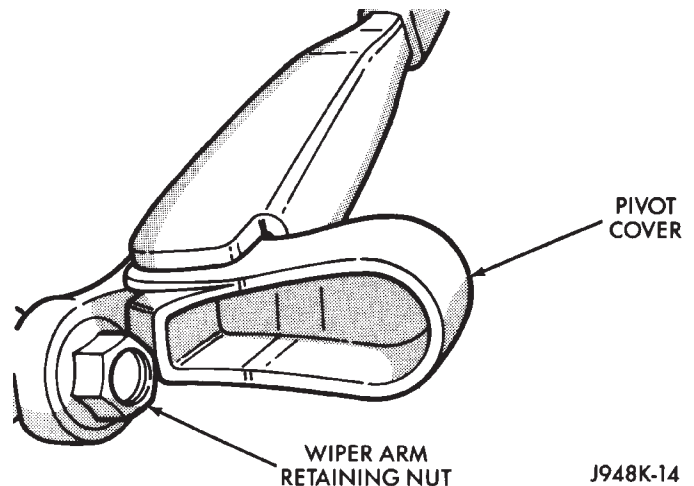

Fig. 8 Rear Wiper Arm Remove/Install

REMOVAL AND INSTALLATION (Continued)

(2) Remove the wiper arm from the motor output shaft using a rocking motion.

(3) Install the rear wiper arm with the wiper blade in the Park position. Place the rear wiper blade in the Installation position on the ramp (Fig. 9) and tighten the retaining nut to 18 N·m (160 in. lbs.).

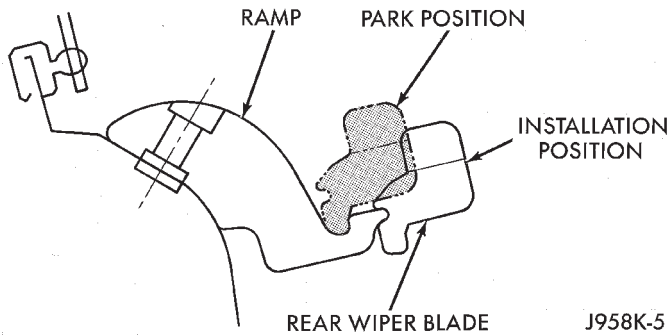

Fig. 9 Rear Wiper Arm Installation

(4) Close the pivot cover and move the rear wiper blade to the Park position on the ramp.

WIPER MOTOR

FRONT

(1) Disconnect and isolate the battery negative cable.

(2) Remove the wiper arms from the wiper pivots. See Wiper Arm in this group for the procedures.

(3) Remove the screws that secure the cowl plenum cover/grille panel to the cowl top panel.

(4) Lift the cowl plenum cover/grille panel from the vehicle far enough to access the windshield washer nozzle plumbing.

(5) Disconnect the windshield washer supply hose from the tee fitting.

(6) Carefully remove the cowl plenum cover/grille panel from the vehicle and set it aside.

(7) Remove the five screws that secure the wiper module to the cowl plenum mounting bracket (Fig. 10).

(8) Move the wiper module far enough to access the wiper motor wire harness connector.

(9) Unplug the wiper motor wire harness connector from the wiper motor.

(10) Remove the wiper module from the cowl plenum as a unit.

(11) Turn the wiper module over and remove the nut that secures the wiper motor crank arm to the wiper motor output shaft.

(12) Remove the three screws that secure the wiper motor to the wiper module mounting bracket.

(13) Remove the wiper motor from the wiper module bracket.

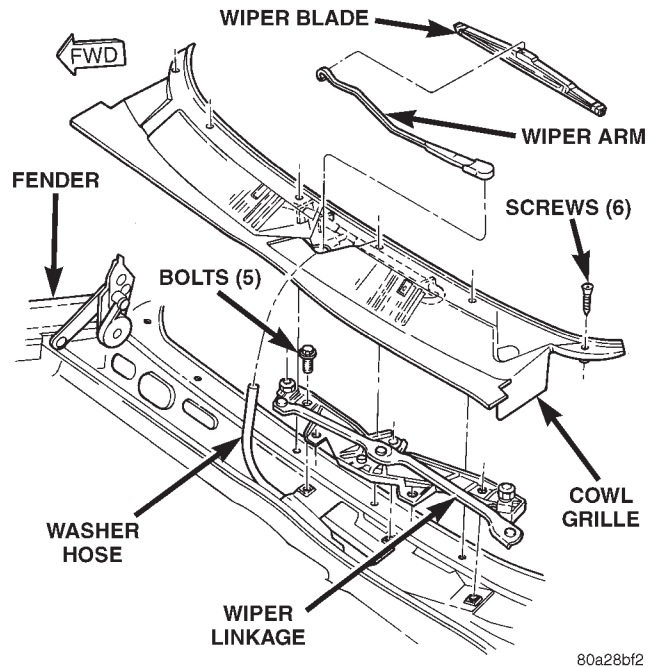

Fig. 10 Wiper Linkage Module Remove/Install

(14) Reverse the removal procedures to install. Tighten the mounting hardware as follows:

- Wiper motor screws - 6 N·m (53 in. lbs.)
- Crank arm nut - 11.5 N·m (101 in. lbs.)
- Wiper module mounting screws - 7.9 N·m (70 in. lbs.).
- Cowl plenum cover/grille panel screws - 1.7 N·m (15 in. lbs.).

REAR

(1) Disconnect and isolate the battery negative cable.

(2) From the outside of the liftgate, remove the rear wiper arm from the rear wiper motor output shaft. See Wiper Arm in this group for the procedures.

(3) From the outside of the liftgate, remove the rear wiper motor output shaft nut (Fig. 11).

(4) Remove the external bezel and gasket from the rear wiper motor output shaft.

(5) From the inside of the liftgate, remove the liftgate inner trim panel. Refer to Group 23 - Body for the procedures.

(6) Unplug the rear wiper motor wire harness connector.

(7) Remove the screws that secure the wiper motor to the liftgate inner panel.

(8) Remove the rear wiper motor from the liftgate.

(9) Reverse the removal procedures to install. Tighten the mounting hardware as follows:

- Motor mounting screws - 1.3 N·m (13 in. lbs.)
- Wiper motor output shaft nut - 5 N·m (42 in. lbs.).

REMOVAL AND INSTALLATION (Continued)

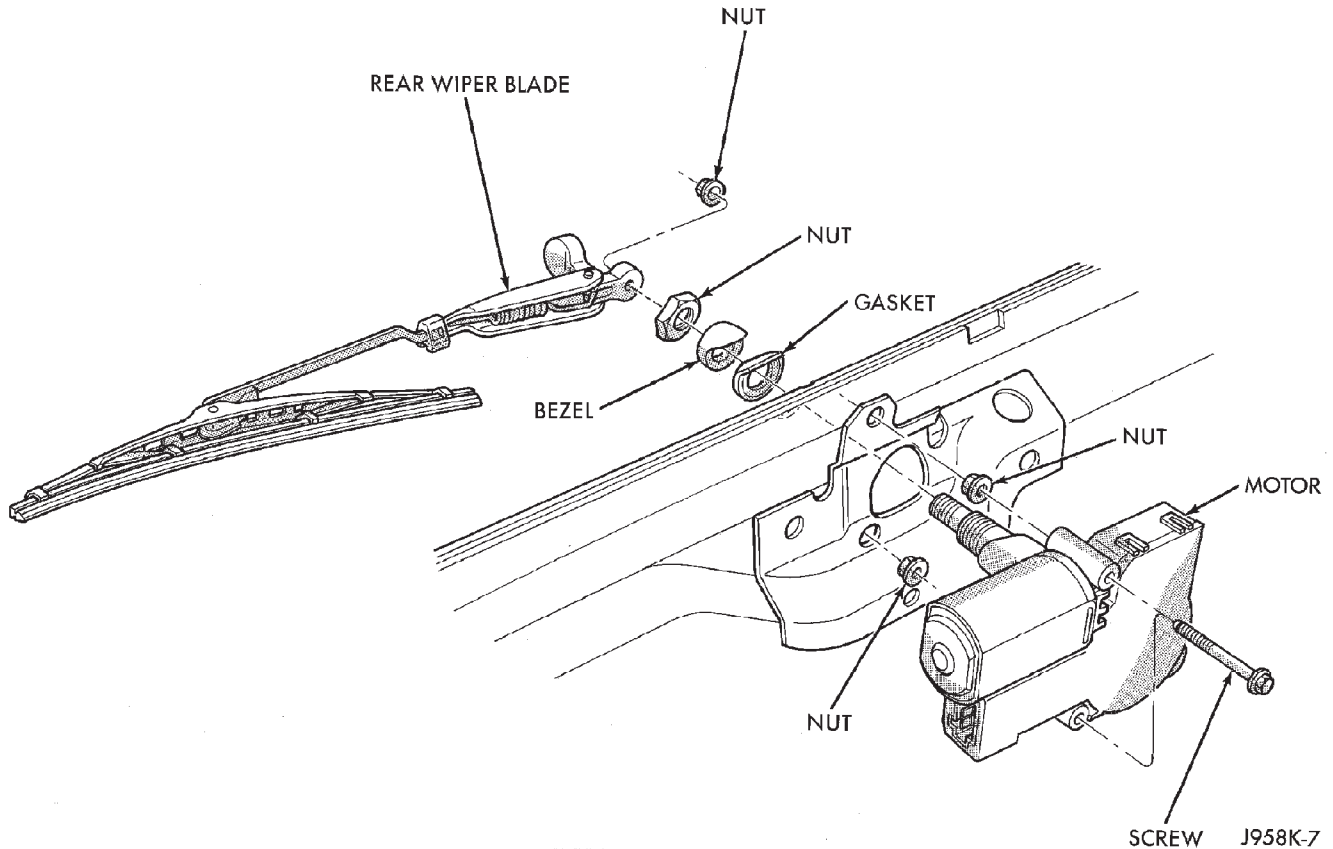

Fig. 11 Rear Wiper Motor Remove/Install

WIPER LINKAGE AND PIVOT

The wiper linkage and pivots can only be removed from or installed in the vehicle as a unit with the wiper motor. See Wiper Motor in this group for the service procedures.

INTERMITTENT WIPE RELAY

- (1) Disconnect and isolate the battery negative cable.
- (2) Remove the cover from the Power Distribution Center (PDC) (Fig. 12).
- (3) Refer to the label on the PDC for intermittent wipe relay identification and location.
- (4) Unplug the intermittent wipe relay from the PDC.
- (5) Install the intermittent wipe relay by aligning the relay terminals with the cavities in the PDC and pushing the relay firmly into place.
- (6) Install the PDC cover.
- (7) Connect the battery negative cable.
- (8) Test the relay operation.

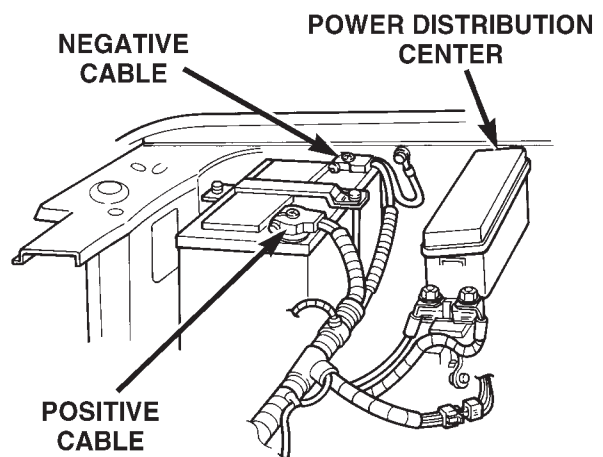

Fig. 12 Power Distribution Center

80a7233a

REMOVAL AND INSTALLATION (Continued)

WIPER SWITCH AND WASHER SWITCH

FRONT

WARNING: ON VEHICLES EQUIPPED WITH AIR-BAGS, REFER TO GROUP 8M - PASSIVE RESTRAINT SYSTEMS BEFORE ATTEMPTING ANY STEERING WHEEL, STEERING COLUMN, OR INSTRUMENT PANEL COMPONENT DIAGNOSIS OR SERVICE. FAILURE TO TAKE THE PROPER PRECAUTIONS COULD RESULT IN ACCIDENTAL AIR-BAG DEPLOYMENT AND POSSIBLE PERSONAL INJURY.

- (1) Disconnect and isolate the battery negative cable.
- (2) If the vehicle is so equipped, remove the tilt steering column lever.
- (3) Using a trim stick or another suitable wide flat-bladed tool, pry gently around the perimeter edges of both instrument panel switch pod bezels to release the snap clip retainers. Remove both bezels from the instrument panel.
- (4) Remove the one screw on each side of the steering column that secures the upper edge of the steering column opening cover/knee blocker to the instrument panel (Fig. 13).

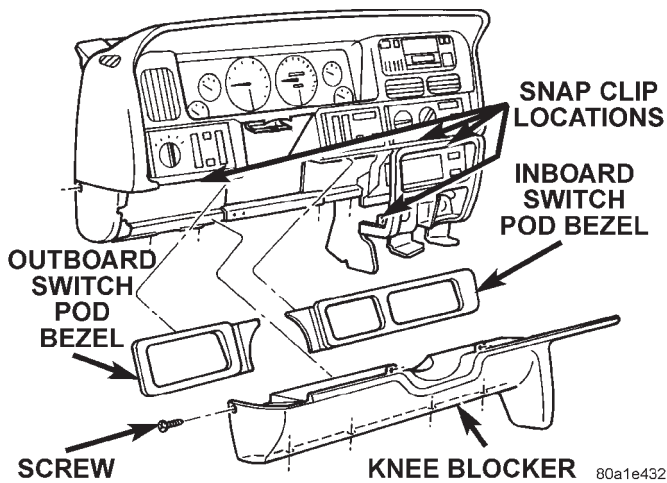

Fig. 13 Steering Column Opening Cover/Knee Blocker Remove/Install

- (5) Remove the one screw that secures the steering column opening cover/knee blocker to the outboard end of the instrument panel.
- (6) Remove the four screws that secure the lower edge of the steering column opening cover/knee blocker to the lower instrument panel reinforcement.
- (7) Using a trim stick or another suitable wide flat-bladed tool, gently pry the edges of the steering column opening cover/knee blocker away from the instrument panel at the snap clip retainer locations (Fig. 13).

- (8) Remove the steering column opening cover/knee blocker from the instrument panel.
- (9) Remove both the upper and lower shrouds from the steering column (Fig. 14).

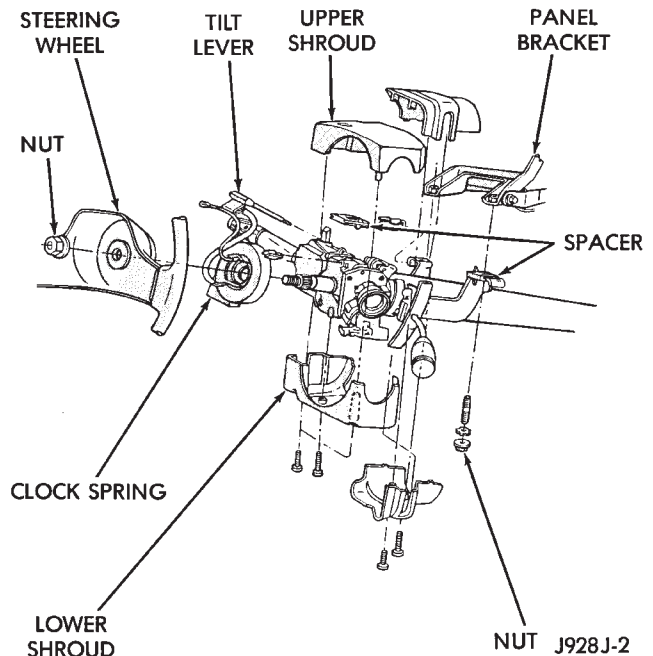

Fig. 14 Steering Column Shrouds Remove/Install - Typical

- (10) Remove the lower fixed column shroud.
- (11) Loosen the nuts that secure the steering column upper mounting bracket to the dash panel steering column support bracket studs. Lower the column far enough to move the upper fixed column shroud.
- (12) Move the upper fixed column shroud far enough to access the rear of the multi-function switch (Fig. 15).
- (13) Remove the tamper proof mounting screws (a Snap On tamper proof torx bit TTXR20B2 or equivalent).

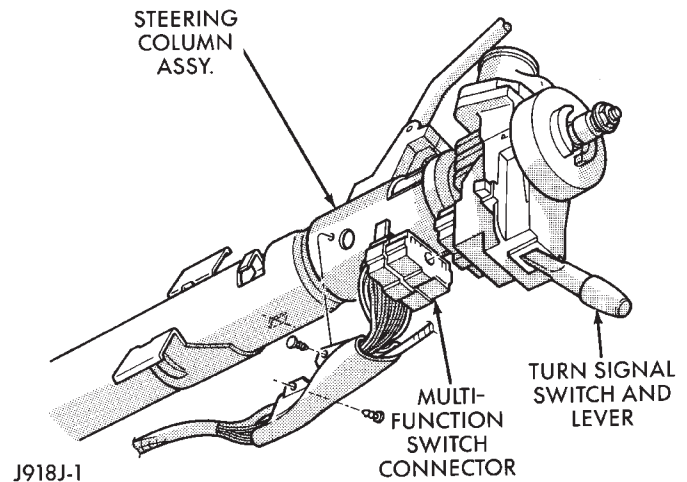

Fig. 15 Multi-Function Switch Connector - Typical

REMOVAL AND INSTALLATION (Continued)

lent is required) that secure the multi-function switch to the steering column.

(14) Gently pull the switch away from the steering column far enough to access and loosen the multi-function switch wire harness connector screw. The screw will remain in the wire harness connector.

(15) Unplug the wire harness connector from the multi-function switch.

(16) Reverse the removal procedures to install. Tighten the fasteners as follows:

- Multi-function switch wire harness connector screw - 2 N-m (17 in. lbs.)
- Multi-function switch mounting screws - 2 N-m (17 in. lbs.)
- Steering column mounting nuts - 12 N-m (110 in. lbs.).

REAR

WARNING: ON VEHICLES EQUIPPED WITH AIRBAGS, REFER TO GROUP 8M - PASSIVE RESTRAINT SYSTEMS BEFORE ATTEMPTING ANY STEERING WHEEL, STEERING COLUMN, OR INSTRUMENT PANEL COMPONENT DIAGNOSIS OR SERVICE. FAILURE TO TAKE THE PROPER PRECAUTIONS COULD RESULT IN ACCIDENTAL AIRBAG DEPLOYMENT AND POSSIBLE PERSONAL INJURY.

(1) Disconnect and isolate the battery negative cable.

(2) Using a trim stick or another suitable wide flat-bladed tool, pry gently around the perimeter edges of the inboard switch pod bezel to release the snap clip retainers. Remove the bezel from the instrument panel.

(3) Remove the three screws that secure the inboard switch pod to the instrument panel (Fig. 16).

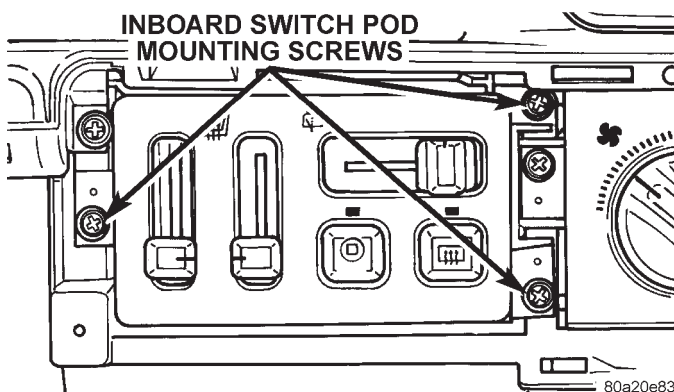

Fig. 16 Inboard Switch Pod Remove/Install

(4) Pull the inboard switch pod out from the instrument panel far enough to access and unplug the wire harness connectors.

(5) Remove the inboard switch pod from the instrument panel.

(6) Reverse the removal procedures to install. Tighten the switch mounting screws to 2.2 N-m (20 in. lbs.).

WASHER SYSTEM

WASHER RESERVOIR

(1) Disconnect and isolate the battery negative cable.

(2) Remove the three screws that secure the washer reservoir to the inner fender shield (Fig. 17).

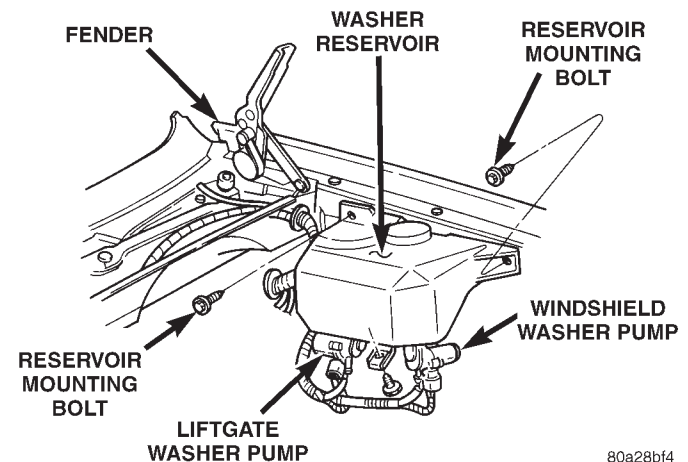

Fig. 17 Washer Reservoir Remove/Install

(3) Lift the reservoir far enough to access the washer pump wire harness connectors and hoses.

(4) Remove the washer supply hoses from the washer pumps and drain the washer fluid from the reservoir into a clean container for reuse.

(5) Unplug the wire harness connectors from the washer pumps and the washer fluid level sensor, if the vehicle is so equipped.

(6) Use a deep socket and extension inserted through the reservoir filler neck to remove the washer pump filter/nuts from the inside of the reservoir.

(7) Remove the washer pumps from the reservoir.

(8) If the vehicle is so equipped, remove the washer fluid level sensor from the reservoir. See Washer Fluid Level Sensor in this group for the procedures.

(9) Remove the rubber grommet seals from the reservoir and discard.

(10) Reverse the removal procedures to install. Always use new rubber grommet seals on the reservoir. Tighten the reservoir mounting screws to 4 N-m (35 in. lbs.).

REMOVAL AND INSTALLATION (Continued)

WASHER PUMP

(1) Disconnect and isolate the battery negative cable.

(2) Remove the washer supply hose from the barbed outlet nipple of the faulty washer pump and drain the washer fluid from the reservoir into a clean container for reuse.

(3) Unplug the wire harness connector from the faulty washer pump.

(4) Use a deep socket and extension inserted through the reservoir filler neck to remove the faulty washer pump filter/nut from the inside of the reservoir.

(5) Remove the faulty washer pump from the reservoir.

(6) Remove the rubber grommet seal from the reservoir and discard.

(7) Reverse the removal procedures to install. Always use a new rubber grommet seal on the reservoir.

WASHER FLUID LEVEL SENSOR

(1) Remove the washer reservoir from the vehicle. See Washer Reservoir in this group for the procedures.

NOTE: The pivoting float of the washer fluid sensor must be in a horizontal position within the reservoir in order to be removed. With the reservoir empty and in an upright position, the pivoting float will orient itself to the horizontal position when the sensor connector is pointed straight downwards.

(2) Using a trim stick or another suitable wide flat-bladed tool, gently pry the washer fluid level sensor out of the rubber grommet seal. Care must be taken not to damage the reservoir.

(3) Remove the rubber grommet seal from the reservoir and discard.

(4) Reverse the removal procedures to install. Always use a new rubber grommet seal on the reservoir.

WASHER NOZZLE**FRONT**

(1) Use a small screwdriver to gently pry the snap-fit nozzle loose from the opening in the cowl plenum cover/grille panel.

(2) Pull the nozzle out from the cowl plenum cover/grille panel far enough to access and disconnect the washer supply hose from the nozzle nipple.

(3) Reverse the removal procedures to install.

REAR

(1) Using a trim stick or another suitable wide flat-bladed tool, pry gently at the lower edge of the rear washer nozzle to release the snap clips that secure it to the liftgate outer panel.

(2) Pull the nozzle out from the liftgate outer panel far enough to access and disconnect the washer supply hose from the nozzle nipple.

(3) Reverse the removal procedures to install.

CHECK VALVE

A check valve is located in the washer supply line in the liftgate opening header, near the grommet where the supply hose exits the vehicle body to the liftgate.

(1) Remove the upper liftgate opening trim panel. Refer to Group 23 - Body for the procedures.

(2) Disconnect the washer supply hoses from the barbed nipples on each end of the rear washer system check valve.

(3) Remove the check valve from the vehicle.

(4) When reinstalling the check valve, be certain the valve is properly oriented within the system flow (Fig. 18).

(5) Reverse the remaining removal procedures to complete the installation.

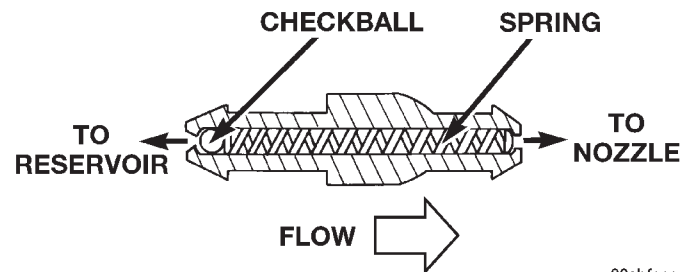

80abfece

Fig. 18 Washer System Check Valve

